

Powerlite

Phone 02 9912 5000 Email sales@powerlite.com.au Website www.powerlite.com.au



GMS42CS-AU

47kVA Standby
42kVA Prime

Technical

Model	GMS42CS
Type	Heavy duty
Speed	1500RPM
Phase/Voltage	3-415
Frequency	50Hz
Standby Power	47kVA
Prime Power	42kVA
Noise Level Av (dba @ 7m)	66dba
Fuel Capacity	270L
Ambient Temp	50deg C

Alternator

Manufacturer	Stamford
Model	PI144K
Type	Brushless
Harmonic Distortion	Less than 5%
Protection Class	IP 23
Insulation Class	Class H

Dimensions & Weight

Length	2.69m
Width	1.10m
Height	1.65m
Weight Dry	1444Kg

Outlets

BUS ONLY
OUTLET PACKAGE AS OPTION

Engine

Manufacturer	Cummins
Model	4BT3.9G2
Type	4 Stroke Diesel
Induction	Turbo Charged
Fuel Consumption	9.3 L/hr @ 100% Load
Coolant Capacity	37L
Governor	Mechanical
Cubic Capacity	3.9 L
Oil Capacity	12.5 L

Controls

Controller	Deep Sea 7420
Circuit Breaker	ABB
Battery Isolator	Fitted
Battery Charger	Fitted

Canopy

Skid	Bunded fuel tank with tie down points and fork lift pockets
Canopy	Centre lift with lockable doors, Galvanized sheet, External Emergency Stop fitted.
Paint Finish	Heavy Duty Powder Coat White with Black base

Options

PMG Coolant Heater Auto Start Installation Service, Synchronising Package, Fire suppression, Mine compliance

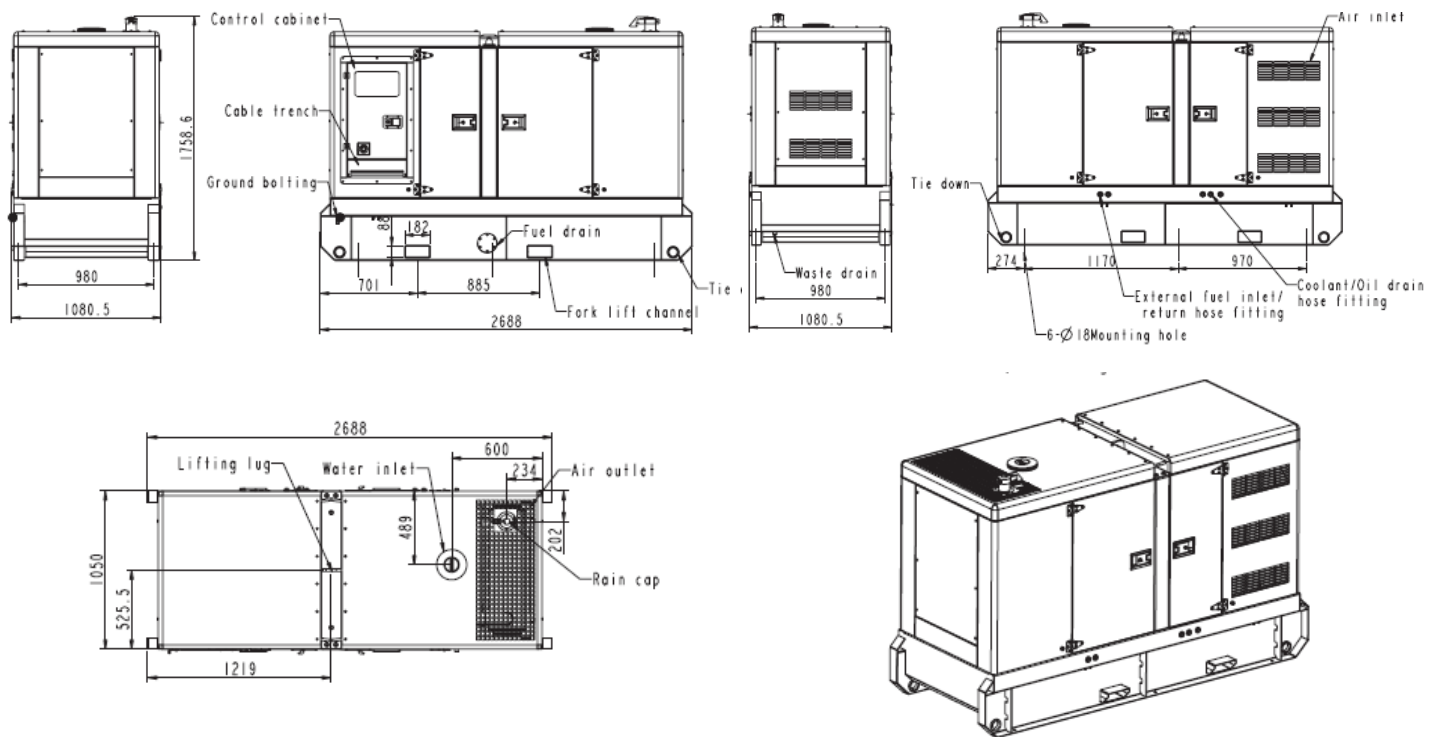

DSE7410/20

AUTO START & AUTO MAINS FAILURE MODULES

FEATURES



DSE7410



DSE7420



KEY FEATURES

- 4-Line back-lit LCD text display
- Five key menu navigation
- Front panel editing with PIN protection
- Customisable status screens
- Power save mode
- 11 configurable inputs
- 8 configurable outputs
- Flexible sensor inputs
- Configurable timers and alarms
- 3 configurable maintenance alarms
- Multiple date and time scheduler
- Configurable event log (250)
- Tier 4 CAN engine support
- Integral PLC editor
- Easy access diagnostic page
- CAN and Magnetic Pick-up/Alt. sensing
- Fuel usage monitor and low fuel alarms
- Charge alternator failure alarm
- Manual speed control (on compatible CAN engines)
- Manual fuel pump control
- Engine exerciser
- "Protections disabled" feature
- kW protection
- Reverse power (kW) protection

- LED and LCD alarm indication
- Power monitoring (kW h, kV Ar, kV A h, kV Ar h)
- Load switching (load shedding and dummy load outputs)
- Automatic load transfer (DSE7420)
- Unbalanced load protection
- Independent Earth Fault trip
- USB connectivity
- Backed up real time clock
- Fully configurable via DSE Configuration Suite PC software
- Configurable display languages
- Remote SCADA monitoring via DSE Configuration Suite PC software
- User selectable simultaneous RS232, RS485 & Ethernet communications
- Configurable MODBUS pages
- MODBUS RTU & TCP support
- Advanced SMS messaging (additional external modem required)
- Additional display screens to help with modern diagnostics
- Idle control for starting
- DSENet® expansion compatible
- 20 parameter data logging

KEY BENEFITS

- 132 x 64 pixel ratio display for clarity
- Real-time clock provides accurate event logging
- Multiple date and time scheduler
- Set maintenance periods can be configured to maintain optimum engine performance
- Built in ethernet communications provides advanced remote monitoring
- Modules can be integrated into building management systems (BMS) using MODBUS
- Increased input and output expansion capability via DSENet®
- Licence-free PC software
- IP65 rating (with supplied gasket) offers increased resistance to water ingress
- PLC editor allows user configurable functions to meet specific application requirements
- Data logging to assist with fault finding